

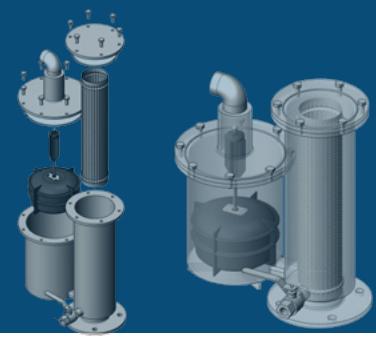

# VS-4-S-HF High Flow

Combination Air Release Valve  
A Breakthrough in Sewage Main Valve Technology



VS-4-S-HF High Flow		
Weight	24 kg	53 lb
Air-Vac Orifice	2826 mm <sup>2</sup>	4.2 in <sup>2</sup>
Auto Orifice	15mm <sup>2</sup>	0.02 in <sup>2</sup>
Anti-surge Orifice	(variable) mm <sup>2</sup>	
Emergency Vacuum Orifice (optional)		
Single	1900mm <sup>2</sup>	2.85 in <sup>2</sup>
Double	3800mm <sup>2</sup>	5.7 in <sup>2</sup>
Others	Optional	

Twin valve chamber model is available. This will double all air flows.

Australia	Table D 100mm (4 hole)
USA	ANSI 4" x 9" (8 hole)

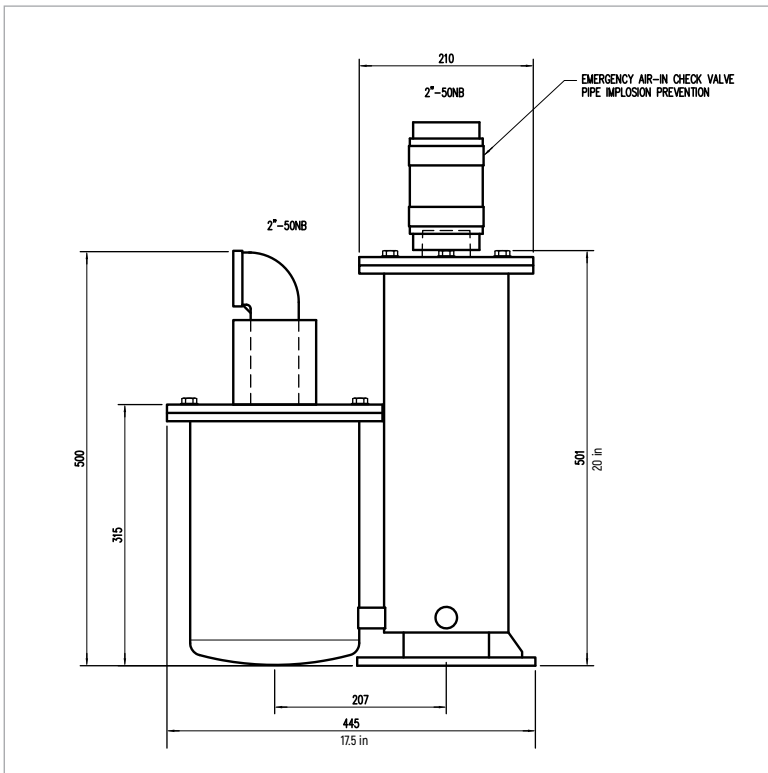

## Air-Vacuum Graph (Hi Flow)

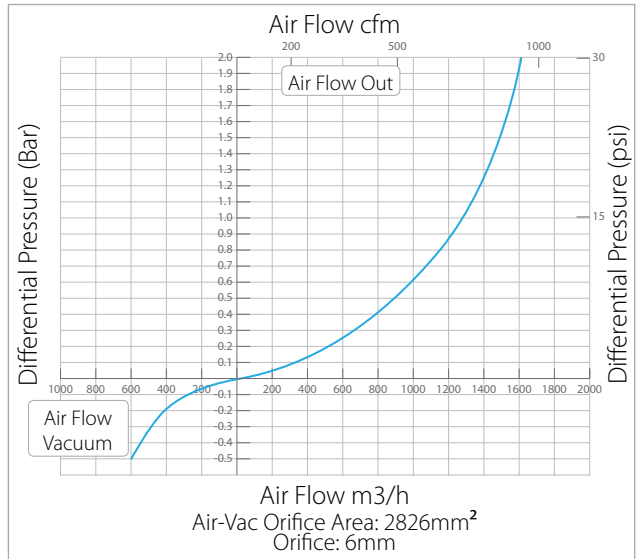

## Optional Adjustable Anti-Surge

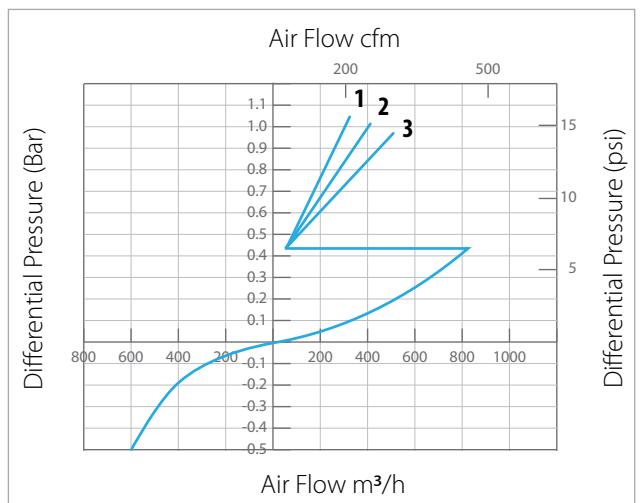

## Optional Emergency Air In Vacuum Control

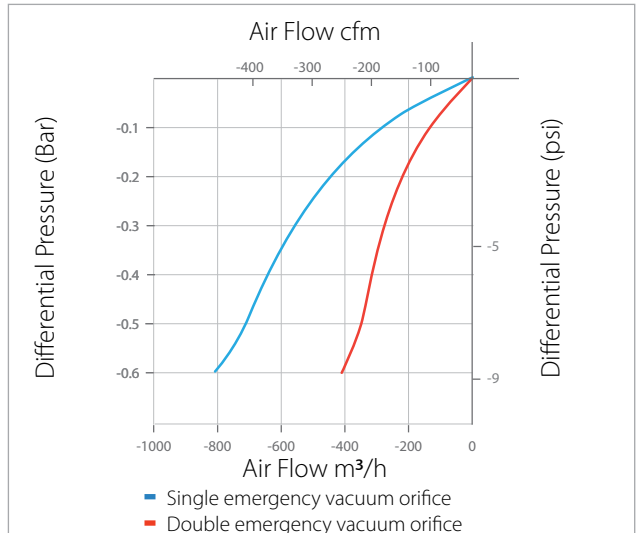

### Australian Distributor:

Australian Designed and Manufactured by  
**Odour Technologies Pty Ltd**

**W:** [www.odourtechnologies.com.au](http://www.odourtechnologies.com.au)

**E:** [enquiries@odourtechnologies.com.au](mailto:enquiries@odourtechnologies.com.au)

**T:** +61 (0)7 3287 7020

### American Distributor:

**Ferguson Waterworks**

**W:** [www.ferguson.com](http://www.ferguson.com)

**E:** [Joe.Gresia@Ferguson.com](mailto:Joe.Gresia@Ferguson.com)

**T:** +01 (858) 391 3700